



# KOHNEN CONCRETE PRODUCTS, INC.

503 GREEN STREET  
GERMANTOWN, IL 62245

618-523-4266

Belleveille 618-277-2120

Fax 618-523-4751

## NORWECO SINGULAIR® AEROBIC TREATMENT PLANT

MODEL 960 - 1500 GPD

APPLICATION: COMMERCIAL  
TREATMENT CAPACITY: 1500 GALLONS PER DAY  
LIQUID CAPACITY: 3400 GALLONS

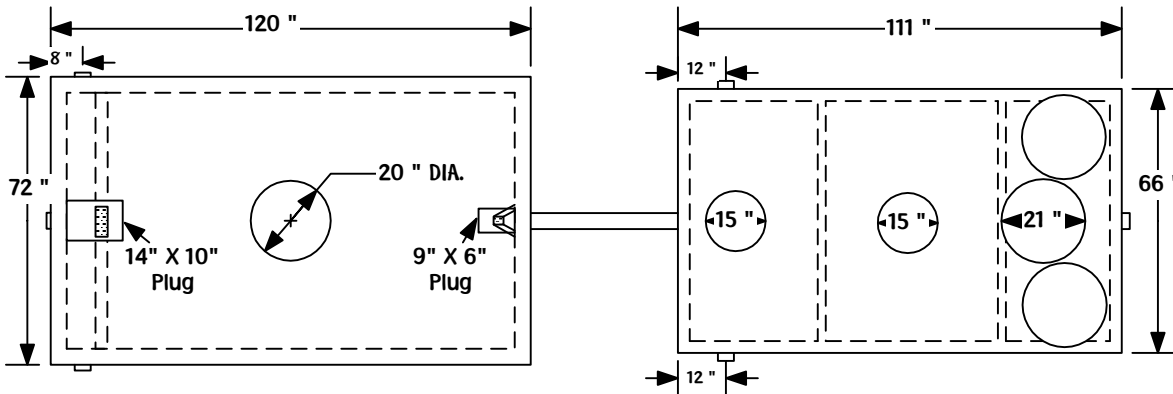
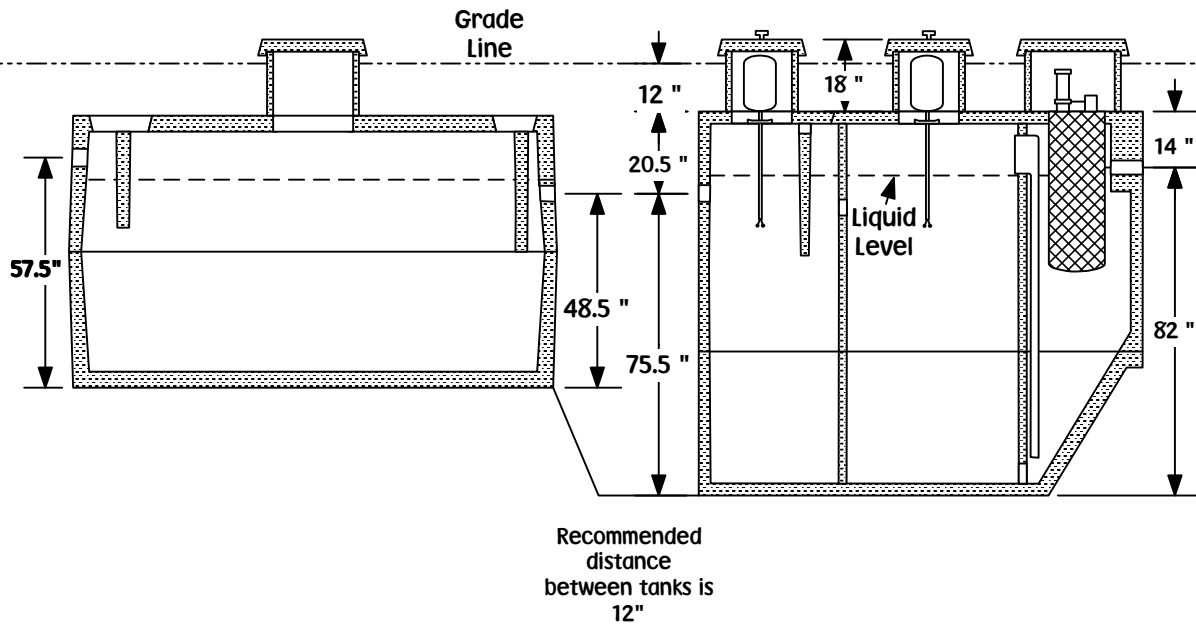

**NOTES:**

1. Excavation Size: 22' x 7', Total depth for normal installation is 9', Deeper installations are possible but our office should be contacted for authorization and specifics.
2. It is critical that tank is level for proper operation of system.
3. A 4" pad of sand or rock should be leveled at bottom of excavation to help assure a level set and to prevent settling. Please note the 27" depth variation between the pretreatment tank and aeration tank.

WEIGHT: 25,315 LBS