



Since 1952

KOHNEN CONCRETE PRODUCTS, INC.

503 GREEN STREET
GERMANTOWN, IL 62245
618-523-4266
Belleville 618-277-2120
Fax 618-523-4751

1500 GALLON 2 COMPARTMENT CONCRETE SEPTIC TANK

EXCAVATION SIZE: 11' 6" L X 7' 6" W

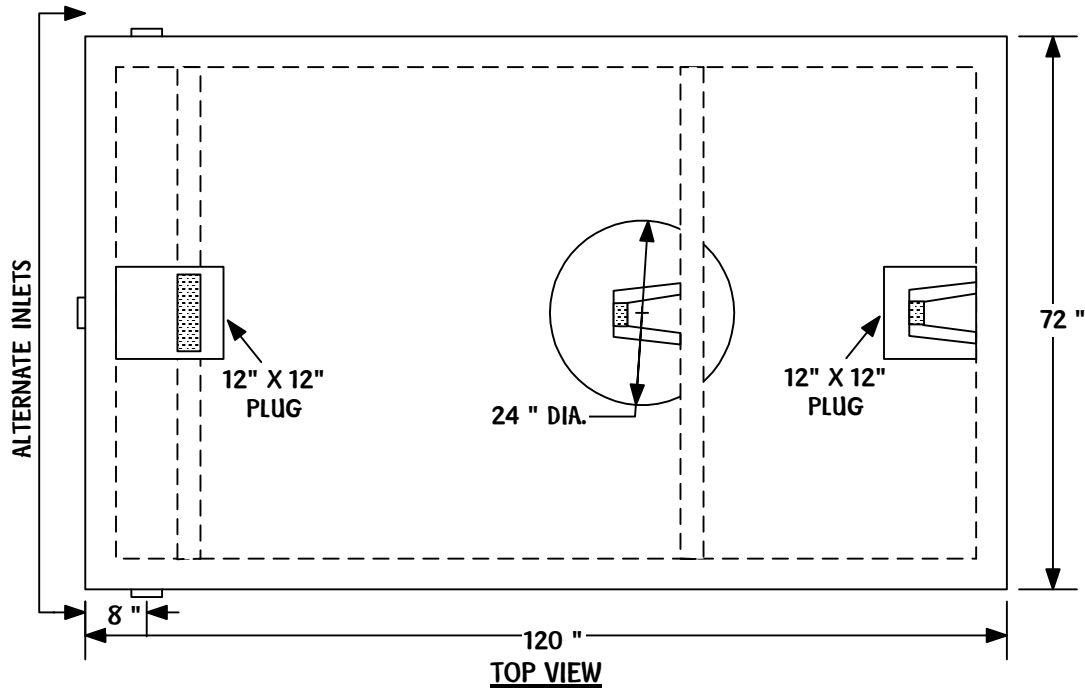
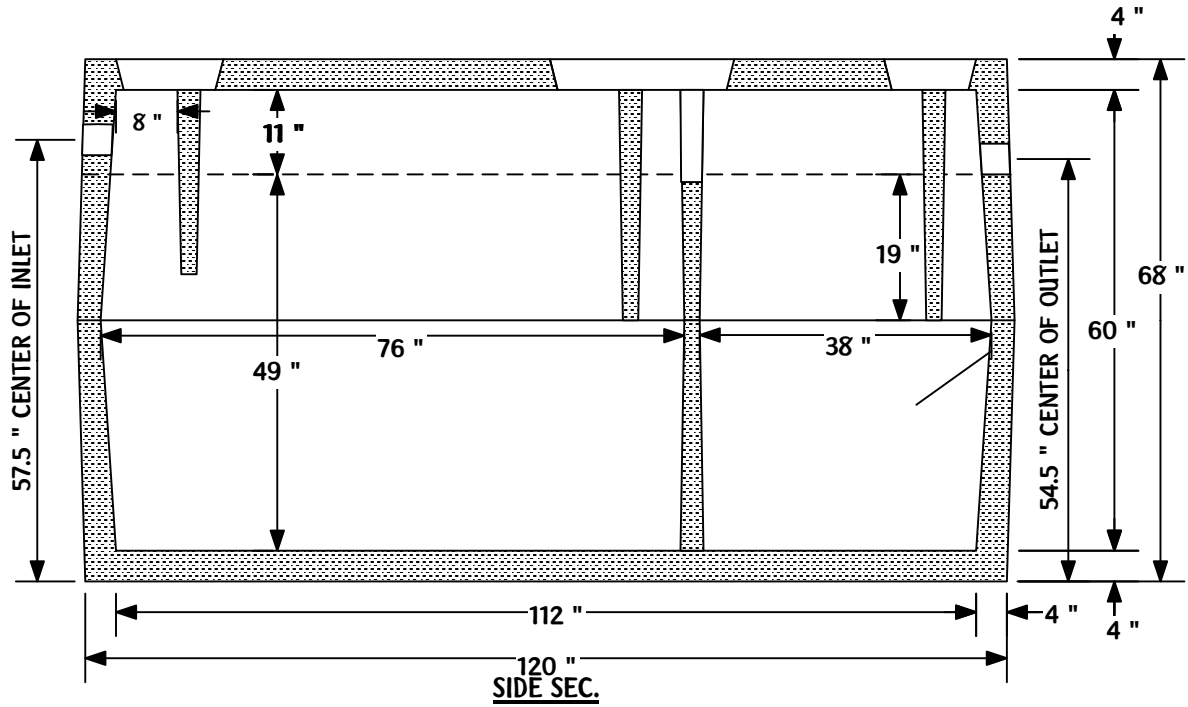

WEIGHT: 11,640 LBS

THIS STRUCTURE IS NOT DESIGNED FOR VEHICULAR TRAFFIC OR MORE THAN 4' OF COVER OVER THE TOP OF THE TANK.